

# TB 9-6625-2076-35

CHANGE 2

DEPARTMENT OF THE ARMY TECHNICAL BULLETIN

---

## CALIBRATION PROCEDURE FOR RECEIVER TEST SET AN/ARM-180 (COLLINS, MODEL 479S-6( ) )

---

Headquarters, Department of the Army, Washington, DC  
16 June 2004

---

*Distribution Statement A: Approved for public release; distribution is unlimited.*

---

TB 9-6625-2076-35, 19 September 2003, is changed as follows:

1. Remove old pages and insert new pages as indicated below. New or changed material is indicated by a vertical bar in the margin of the page.

**Remove Pages**  
11 and 12

**Insert Pages**  
11 and 12

2. File this change sheet in front of the publication for reference purposes.

**By Order of the Secretary of the Army:**

Official:

**PETER J. SCHOOMAKER**  
*General, United States Army*  
*Chief of Staff*

  
**JOEL B. HUDSON**  
*Administrative Assistant to the*  
*Secretary of the Army*

0411012

Distribution:

To be distributed in accordance with IDN 342219, requirements for TB 9-6625-2076-35.

# TB 9-6625-2076-35

CHANGE 1

DEPARTMENT OF THE ARMY TECHNICAL BULLETIN

## CALIBRATION PROCEDURE FOR RECEIVER TEST SET AN/ARM-180 (COLLINS, MODEL 479S-6( ) )

Headquarters, Department of the Army, Washington, DC

1 March 2004

*Distribution Statement A: Approved for public release; distribution is unlimited.*

TB 9-6625-2076-35, 19 September 2003, is changed as follows:

1. Remove old pages and insert new pages as indicated below. New or changed material is indicated by a vertical bar in the margin of the page.

### Remove Pages

1 and 2  
3 and 4  
5 and 6

### Insert Pages

1 and 2  
3 and 4  
5 and 6

2. File this change sheet in front of the publication for reference purposes.

### By Order of the Secretary of the Army:

Official:



**JOEL B. HUDSON**

*Administrative Assistant to the  
Secretary of the Army*

**PETER J. SCHOOMAKER**

*General, United States Army  
Chief of Staff*

0400507

Distribution:

To be distributed in accordance with IDN 342219, requirements for TB 9-6625-2076-35.

# \*TB 9-6625-2076-35

DEPARTMENT OF THE ARMY TECHNICAL BULLETIN

## CALIBRATION PROCEDURE FOR RECEIVER TEST SET AN/ARM-180 (COLLINS, MODEL 479S-6( ) )

Headquarters, Department of the Army, Washington, DC  
19 September 2003

*Distribution Statement A: Approved for public release; distribution is unlimited*

### REPORTING OF ERRORS AND RECOMMENDING IMPROVEMENTS

You can improve this manual. If you find any mistakes or if you know of a way to improve these procedures, please let us know. Mail your letter or DA Form 2028 (Recommended Changes to Publications and Blank Forms) directly to: Commander, US Army Aviation and Missile Command, AMSAM-MMC-MA-NP, Redstone Arsenal, AL 35898-5000. A reply will be furnished to you. You may also provide DA Form 2028 information to AMCOM via e-mail, fax, or the World Wide Web. Our fax number is DSN 788-6546 or Commercial 256-842-6546. Our e-mail address is [2028@redstone.army.mil](mailto:2028@redstone.army.mil). Instructions for sending an electronic 2028 may be found at the back of this manual. For the World Wide Web, use <https://amcom2028.redstone.army.mil>.

SECTION		Paragraph	Page
I.	IDENTIFICATION AND DESCRIPTION		
	Test instrument identification .....	1	2
	Forms, records, and reports .....	2	2
	Calibration description .....	3	2
II.	EQUIPMENT REQUIREMENTS		
	Equipment required .....	4	3
	Accessories required .....	5	3
III.	CALIBRATION PROCESS		
	Preliminary instructions .....	6	4
	Equipment setup .....	7	4
	Frequency .....	8	5
	Frequency response .....	9	6
	Output attenuator .....	10	7
	Modulation tone frequency .....	11	8
	Modulation tone distortion .....	12	8
	FM deviation (zero beat method) .....	13	8
	Radial accuracy .....	14	10
	Localizer DDM .....	15	10
	Glideslope DDM .....	16	12
	AM modulation .....	17	13
	Power supply .....	18	14
	Final procedure .....	19	14

\*This bulletin supersedes TB 9-6625-2076-35, 25 November 1987, including all changes.

**SECTION I  
IDENTIFICATION AND DESCRIPTION**

**1. Test Instrument Identification.** This bulletin provides instructions for the calibration of Receiver Test Set, AN/ARM-180 (Collins, Model 479S-6( ) ). TM 11-6625-2975-40 was used as the prime data source in compiling these instructions. The equipment being calibrated will be referred to as the TI (test instrument) throughout this bulletin.

**a. Model Variations.** None.

**b. Time and Technique.** The time required for this calibration is approximately 4 hours, using the dc and low frequency technique.

**2. Forms, Records, and Reports**

**a.** Forms, records, and reports required for calibration personnel at all levels are prescribed by TB 750-25.

**b.** Adjustments to be reported are designated (R) at the end of the sentence in which they appear. When adjustments are in tables, the (R) follows the designated adjustment. Report only those adjustments made and designated with (R).

**3. Calibration Description.** TI parameters and performance specifications which pertain to this calibration are listed in table 1.

Table 1. Calibration Description

Test instrument parameters	Performance specifications
Output frequency	Range: 74.6 to 335 MHz Accuracy: ±0.0002%
Output level <sup>1</sup>	Range: -6 to -120 dBm (112 mV to 0.22 μV) Accuracy: -6 to -60 dBm, ±1.5 dB -60 to -120 dBm, ±2.0 dB
Modulation tone	Frequency: 30 Hz variable Accuracy: ±0.005%
Modulation tone distortion	Range: 30, 30 VAR, 1020, 9960, 90, 150, 400, 1300, and 3000 Hz Accuracy: 0.25% at 30, 30 VAR, 90 and 150 Hz 0.5% at 1020 and 9960 Hz 1.0% at 400, 1300, and 3000 Hz
Amplitude modulation	Range: 20, 30, 40, 80, and 95% Accuracy: ±2.5% at 20, 30, 40, and 80% ±5% at 95%
FM deviation	Frequency: 480 Hz Accuracy: ±2 Hz
Localizer DDM	Range: ±0.400 in 0.001 increments Accuracy: On course, 0.00056 DDM Off course, 0.00056 DDM +2.5% DDM
Glideslope DDM	Range: ±0.800 in 0.001 increments Accuracy: On course, 0.00102 DDM Off course, 0.00102 DDM +2.5% DDM
VOR radial <sup>2</sup>	Range: 0 to 359.99° Accuracy: ±0.14 <sup>0</sup>

<sup>1</sup>Verified to -20 dB mW on TI.

<sup>2</sup>Accuracy referenced to standard used in calibration.

**SECTION II  
EQUIPMENT REQUIREMENTS**

**4. Equipment Required.** Table 2 identifies the specific equipment to be used in this calibration procedure. This equipment is issued with Secondary Transfer Calibration Standards Set AN/GSM-287 or AN/GSM-705. Alternate items may be used by the calibrating activity when the equipment listed in table 2 is not available. The items selected must be verified to perform satisfactorily prior to use and must bear evidence of current calibration. The equipment must meet or exceed the minimum use specifications listed in table 2. The accuracies listed in table 2 provide a four-to-one ratio between the standard and TI.

**5. Accessories Required.** The accessories required for this calibration are common usage accessories, issued as indicated in paragraph 4 above, and are not listed in this calibration procedure. The following peculiar accessory is also required for this calibration: Clarostat Model 240C (7907234), Decade Resistor, (two required).

Table 2. Minimum Specifications of Equipment Required

Common name	Minimum use specifications	Manufacturer and model (part number)
AUDIO ANALYZER	Distortion Range: 30 Hz to 3 kHz	Boonton, Model 1121 (1121)
DIGITAL MULTIMETER	Range: 0 to 10 V ac Accuracy: $\pm 0.01\%$ Range: 5 V dc Accuracy: $\pm 2.5\%$	Hewlett-Packard, Model 3458A/E02 (MIS35947/1)
FREQUENCY COUNTER	Range: 9,960 Hz to 335 MHz Accuracy: $5 \times 10^7$	Fluke, Model PM6681
MEASURING RECEIVER	Range: 20 to 95% modulation Accuracy: $\pm 0.5\%$	Hewlett-Packard, Model 8902A with power sensor Hewlett-Packard, Model 11722A (7917002 or 7911261)
OSCILLOSCOPE	Range: 9.96 kHz Accuracy: $\pm 3\%$	Tektronix, Model 2430A (OS-291/G)
POWER METER	Range: 0 to -20 dBm Accuracy: $\pm 4\%$	Hewlett-Packard, Model 437B (13440045) w/power sensor, Hewlett-Packard, Model 8482A (13440043)
SYNTHESIZER/LEVEL GENERATOR	Frequency range: 9475 to 10,442 Hz Accuracy: $\pm 0.5\%$	Hewlett-Packard, Model 3335A (MIS-35938)
ZIFOR III <sup>1</sup>	Range: 0 to 359.99 <sup>0</sup>	Collins, Model 478A3 (478A3)

<sup>1</sup>Limited deployed.

### SECTION III CALIBRATION PROCESS

#### 6. Preliminary Instructions

a. The instructions outlined in paragraphs 6 and 7 are preparatory to the calibration process. Personnel should become familiar with the entire bulletin before beginning the calibration.

b. Items of equipment used in this procedure are referenced within the text by common name and item identification number as listed in tables 2 and 3. For the identification of equipment referenced by item numbers prefixed with A, see table 2, and for prefix B, see table 3.

c. Unless otherwise specified, verify the result of each test and, whenever the test requirement is not met, take corrective action before continuing with the calibration. Adjustments required to calibrate the TI are included in this procedure. Additional maintenance information is contained in TM 11-6625-2975-40 for this TI.

d. When indications specified in paragraphs 8 through 17 are not within tolerance, perform the power supply check prior to making adjustments. After adjustments are made, repeat paragraphs 8 through 17. Do not perform power supply check if all other parameters are within tolerance.

e. Unless otherwise specified, all controls and control settings refer to the TI.

#### 7. Equipment Setup

##### WARNING

HIGH VOLTAGE is used or exposed during the performance of this calibration. DEATH ON CONTACT may result if personnel fail to observe safety precautions. REDUCE OUTPUT(S) to minimum after each step within the performance check where applicable.

a. Remove protective cover from TI.

b. Connect TI to a 115 V ac source.

c. Energize equipment and allow at least 30 minutes for equipment to warmup and stabilize.

##### NOTE

A computer memory check is performed immediately after power is turned on. If an incorrect output occurs, the number of the malfunctioning memory is displayed on the **RDL/DDM/MOD** display and **MODE** display **SELF TEST** indicator is lit momentarily, then the memory chip number and **SELF TEST** indicator flash on and off. TI must be repaired before continuing.

d. Press and hold **SELF TEST**. All 8's will appear on **RDL/DDM/MOD**, **FREQUENCY**, and **RF LEVEL** display.

e. Release **SELF TEST** pushbutton. **RDL/DDM/MOD** display will count. If memory chip output is incorrect, an error code will be displayed. TI must be repaired before continuing.

f. When **RDL/DDM/MOD** display finishes counting, self-test cycle is complete. TI will be in preset **108.000 MHz VOR** mode.

**NOTE**

In paragraphs 8 through 17 below, when frequency is changed, the TI will automatically select proper modulation for frequency selected. Press any **TONE SELECT** pushbuttons that are lit to obtain an unmodulated signal unless instructed otherwise.

**8. Frequency**

**a. Performance Check**

(1) Connect frequency counter to TI **RF OUT**.

(2) Press all **TONE SELECT** pushbuttons to off position (not lit).

(3) Press **RF SELECT FAST** and **SLOW DECR** or **FAST** and **SLOW INCR** pushbuttons as required for a **RF LEVEL** display of -6 dBmW. If frequency counter does not indicate between 107.999784 and 108.000216 MHz, perform **b** below.

**NOTE**

To enter a frequency into TI, **RF SELECT RF FREQ** pushbutton must be lit. Then press **DATA ENTRY** pushbuttons for desired frequency and press **ENTER**. If an error is made while entering frequency and before **ENTER** is pressed, press **CLEAR** and re-enter correct frequency.

(4) Enter frequencies listed in table 4 into TI. Frequency counter will indicate within limits specified.

Table 4. Frequency Accuracy

Test instrument frequency (MHz)	Frequency counter indications (MHz)	
	Min	Max
74.600	74.599851	74.600149
75.400	75.399849	75.400151
117.950	117.949764	117.950236
329.150	329.149342	329.150658
335.000	334.999330	335.000670

(5) Enter a frequency of 108.000 MHz into TI.

(6) Press **RF SELECT ΔF** pushbutton

(7) Press and hold **SLOW DECR** pushbutton. TI **FREQUENCY** indication will decrease. Release pushbutton.

**TB 9-6625-2076-35**

(8) Press and hold **FAST DECR** pushbutton until frequency stops decreasing. Frequency counter will indicate less than 107.9730 MHz.

(9) Press and hold **SLOW INCR** pushbutton. TI **FREQUENCY** indication will increase. Release pushbutton.

(10) Press and hold **FAST INCR** pushbutton until frequency stops increasing. Frequency counter will indicate greater 108.0270 MHz.

(11) Press **RF SELECT**  $\Delta F$  pushbutton off.

**b. Adjustments.** Adjust TCXO ADJ (located on A4A4 assembly) for a 108.00 MHz frequency counter indication (R).

**9. Frequency Response**

**a. Performance Check**

(1) Press all TI **TONE SELECT** pushbuttons to off position (not lit).

(2) Connect power meter to TI **RF OUT**.

(3) Enter a frequency of 108.000 MHz into TI. Power meter indication will be between -5.5 and -6.5 dBm.

(4) Enter frequencies listed in table 5 into TI. If power meter does not indicate between -5.5 and -6.5 dBm at each frequency, adjust corresponding adjustment listed in table 5 for a -6 dBm power meter indication. If any adjustment is made, repeat (2) above.

Table 5. Frequency Response  
Test instrument

Frequencies (MHz)	Adjustments (Fig. 1a) (R)
74.60	---
75.00	R7
75.40	---
110.00	---
111.95	---
113.00	R8
114.00	---
116.00	---
117.95	---
329.15	---
331.10	---
332.00	R6
333.50	---
335.00	---

**b. Adjustments.** No further adjustments can be made.



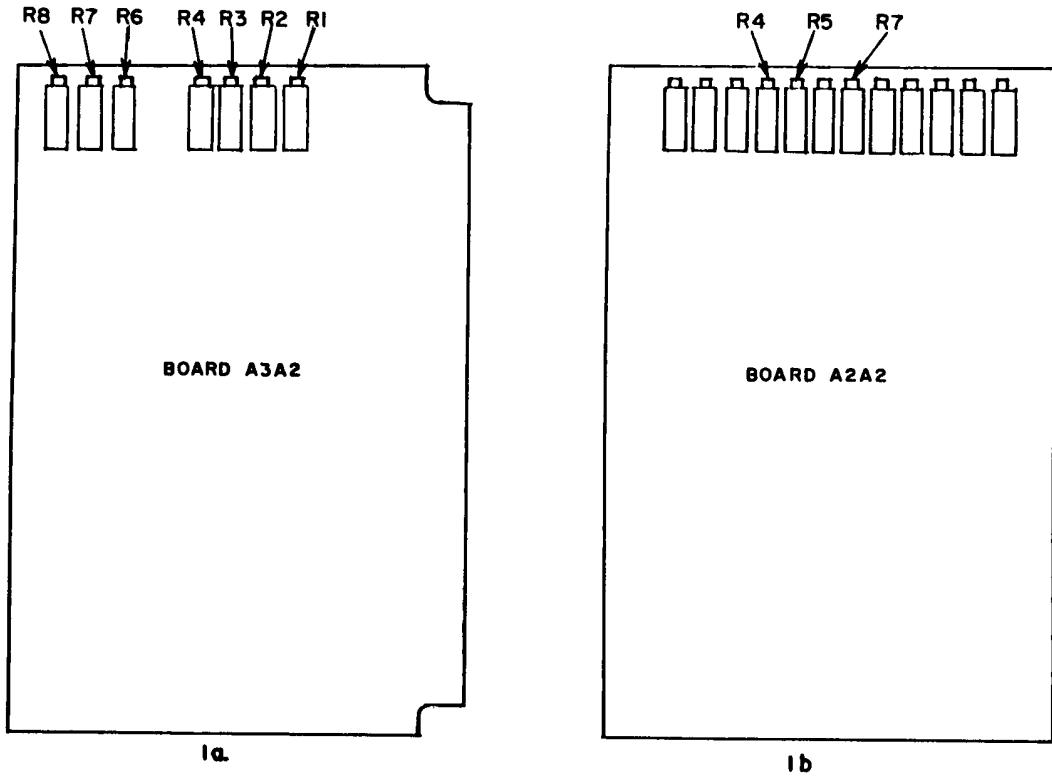

Figure 1. Demodulator/ALC board A3A2 and analog board A2A2.

**10. Output Attenuator**

**a. Performance Check**

- (1) Enter a frequency of 108.000 MHz into TI. Record exact power meter indication.
- (2) Enter **RF LEVELS** listed in table 6 into TI. The change in power meter indication from that recorded in (1) above will be within limits specified.

**b. Adjustments.** No adjustments can be made.

Table 6. Output Attenuator

Test instrument RF level	Power meter difference indications (dBm)	
	Min	Max
-7	0	-2
-8	-1	-3
-10	-3	-5
-14	-7	-9
-20	-13	-15

**11. Modulation, Tone Frequency**

**a. Performance Check**

**NOTE**

Since all of the audio tones are derived from the same reference crystal, only the accuracy of one tone is checked.

- (1) Connect frequency counter to TI **COMP** (rear panel).
- (2) Enter a frequency of 108.000 MHz into TI and press **TONE SELECT 9960 Hz** pushbutton (all other **TONE SELECT** pushbuttons off).
- (3) Measure period of 9960 Hz tone. Frequency counter will indicate between 100.39658 and 100.40662  $\mu$ s. If not, perform **b** below.

**b. Adjustments.** Adjust A2A3C7 (located on left side of TI, top front of board A2A3) for a 100.4016  $\mu$ s frequency counter indication (R).

**12. Modulation Tone Distortion**

**a. Performance Check**

- (1) Connect audio analyzer to TI **COMP** (rear panel).
- (2) Measure distortion, using standard measurement techniques. Distortion will be 0.5 percent or less.
- (3) Repeat technique of (2) above for TI frequencies and indications listed in table 7. Distortion will be within limits specified.

Table 7. Modulation Tone Distortion

Test instrument		Distortion analyzer maximum distortion (%)
Frequency (MHz)	<b>TONE SELECT</b> (Hz)	
108.00	1020	0.5
332.00	90	0.25
332.00	150	0.25
75.00	400	1.0
75.00	1300	1.0
75.00	3000	1.0

**13. FM Deviation (Zero Beat Method)**

**a. Performance Check**

- (1) Position oscilloscope controls as listed in (a) through (d) below:
  - (a) **VERTICAL MODE** to **CH1 vs CH2** and **XY**.
  - (b) **CH1** and **CH2 VOLTS/DIV** to **.5 V**.
  - (c) **CH1** and **CH2 COUPLING/INVERT** t

- (2) Connect TI **COMP** (rear) to **CH2 INPUT** on oscilloscope, and synthesizer/level generator **OUTPUT 50  $\Omega$**  to **CH1 INPUT** of oscilloscope.
- (3) Enter a frequency of 108.000 MHz into TI and press **TONE SELECT 9960 FM** only (**30 Hz VAR OFF**) pushbutton.
- (4) Adjust oscilloscope **CH2 VOLT/DIV VARIABLE** control for a 4-division vertical deflection on crt.
- (5) Adjust synthesizer/level generator frequency to 9475 Hz and output amplitude controls for a 4-division horizontal deflection on **CH 1** of oscilloscope crt.
- (6) The crt will display a 4-division square pattern with a slowly oscillating circle or ellipse inside the square pattern as shown in figure 2.

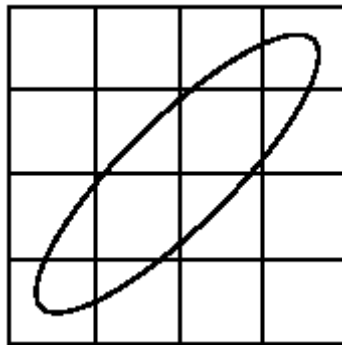

Figure 2. Typical FM Deviation Oscilloscope Display (Zero Beat Method).

- (7) Slowly adjust synthesizer/level generator frequency to stop rotation of ellipse on oscilloscope crt and record synthesized level generator frequency indication.

**NOTE**

A slight drift is acceptable.

- (8) Adjust synthesizer/level generator frequency to 10,435 Hz and repeat (7) above.
- (9) Subtract frequency recorded in (7) above from frequency measured in (8) above and divide the difference by 2. The quotient will be between 478 and 482 Hz.

**b. Adjustments.** No adjustments can be made.

**14. Radial Accuracy**

**a. Performance Check**

- (1) Connect ZIFOR III input to TI **COMP** output (rear panel).
- (2) Press **TONE SELECT 30 Hz VAR** and **9960 FM** pushbuttons (all other **TONE SELECT** pushbuttons off).
- (3) Press **FUNCTION/CONTROL RDL/DDM** pushbutton and enter 000.00 into TI for a **FROM 000.00 RDL/DDWDMOD** indication. ZIFOR III indications will be between 359.86 to 0.14 degrees radial.
- (4) Enter **RDL (DEG)** settings listed in table 8 into TI. ZIFOR III indications will be within limits specified.

**NOTE**

Proper 30 degree radial steps can be entered by pressing **FUNCTION/ CONTROL STEP ΔRDL ΔDDM** pushbuttons.

Table 8. Radial Accuracy (Audio)

Test instrument RDL (DEG)	ZIFOR III indications (DEG)	
	Min	Max
030.00	029.86	030.14
060.00	059.86	060.14
090.00	089.86	090.14
120.00	119.86	120.14
150.00	149.86	150.14
180.00	179.86	180.14
210.00	209.86	210.14
240.00	239.86	240.14
270.00	269.86	270.14
300.00	299.86	300.14
330.00	329.86	330.14

- b. Adjustments.** No adjustments can be made.

**15. Localizer DDM**

**a. Performance Check**

- (1) Connect digital multimeter to TI **COMP** output (rear panel).
- (2) Press **FUNCTION/CONTROL STD** pushbutton and enter a frequency of 108.10 MHz into TI.
- (3) Press **TONE SELECT 90 Hz** pushbutton (all other **TONE SELECT** pushbuttons off). Record digital multimeter indication
- (4) Press **TONE SELECT 150 Hz** pushbutton (all other **TONE SELECT** pushbuttons off). Record digital multimeter indication.
- (5) Divide the measured value of one tone by the other to determine the voltage ratio. If calculated ratio is not between 0.99950 and 1.00050, perform **b** (1) through (3) below.

(6) Press **TONE SELECT 1020 Hz** pushbutton (all other **TONE SELECT** pushbuttons off). If digital multimeter does not indicate between 1.4985 and 1.5015 V rms, perform **b** (4) below.

(7) Connect digital multimeter to TI **DEMOD** output (rear panel). Repeat (3) through (5) above. Calculated ratio will be between 0.99720 and 1.00280.

(8) Connect equipment as shown in figure 3.

(9) Set each decade resistor to 47 k $\Omega$ .

(10) Press **TONE SELECT 90 Hz** pushbutton (all other **TONE SELECT** pushbuttons off) and enter a **DDM** setting of 0.046 into TI. Record digital multimeter indication.

(11) Press **TONE SELECT 150 Hz** pushbuttons (all other pushbuttons off). Record digital multimeter indication.

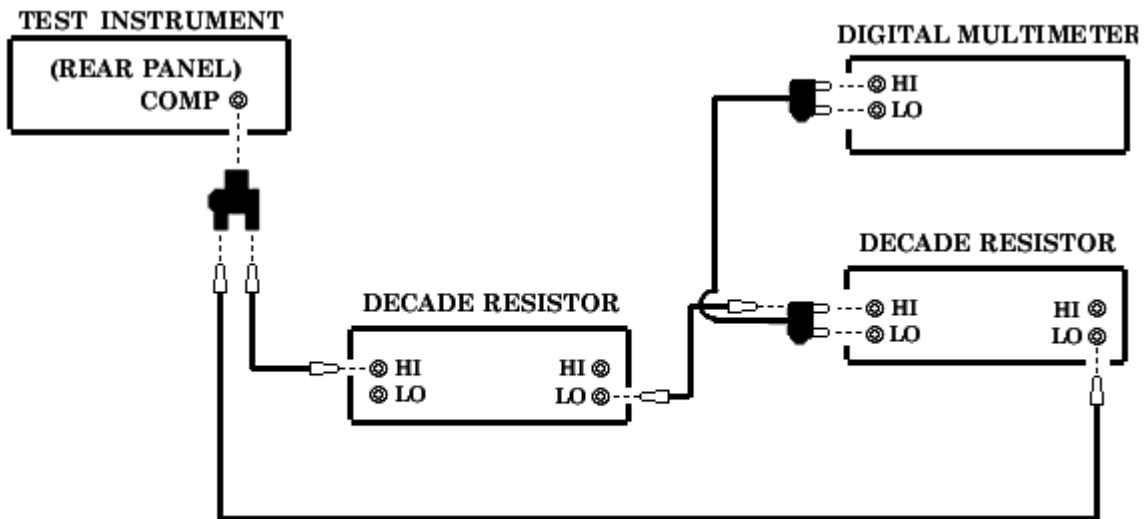

Figure 3. Localizer DDM - equipment setup.

**NOTE**

Proper **DDM** steps can be entered by pressing **FUNCTION/CONTROL STEP  $\Delta$ RDL  $\Delta$ DDM** pushbutton.

(12) Divide value recorded in (11) above by value recorded in (10) above. Calculated ratio will be between 1.25861 and 1.26116.

(13) Repeat technique of (10) through (12) above for each **DDM** setting listed in table 9. Calculated ratio will be within limits specified.

Table 9. Localizer DDM

Test instrument DDM settings	Calculated ratio limits	
	Min	Max
0.093	1.60417	1.60756
0.155	2.26264	2.26797
0.200	2.99600	3.00400

(14) Set **DDM** to **.046** and press **FUNCTION/CONTROL T/F U/L D/R** pushbutton.

(15) Repeat (10) through (13) except to calculate ratio divide value recorded in (10) above by value recorded in (11) above.

**b. Adjustments**

(1) Alternately press **TONE SELECT 90 Hz** and **150 Hz** pushbuttons (only one **TONE SELECT** pushbutton on at a time) and adjust R7 (fig. 1b) until voltage between the two tones is within 50  $\mu$ V (R).

(2) Press **TONE SELECT 150 Hz** pushbutton (all other **TONE SELECT** pushbuttons off). Adjust R4 (fig. 1b) for a 1 V rms indication on digital multimeter (R).

(3) Press **TONE SELECT 90 Hz** pushbutton. If digital multimeter does not indicate 1 V rms, repeat (1) and (2) above until correct indications are obtained.

(4) Adjust R5 (fig. 1b) for a 1.500 V rms indication on digital multimeter (R).

**16. Glideslope DDM**

**a. Performance Check**

(1) Connect digital multimeter to **TI COMP** output (rear panel).

(2) Press **FUNCTION/CONTROL STD** pushbutton and enter a frequency of 335.00 MHz into TI.

(3) Press **TONE SELECT 90 Hz** pushbutton (all other **TONE SELECT** pushbuttons off). Record digital multimeter indication.

(4) Press **TONE SELECT 150 Hz** pushbutton (all other **TONE SELECT** pushbuttons off). Record digital multimeter indication.

(5) Divide the measured value of one tone by the other to determine the voltage ratio. Calculated ratio will be between 0.99975 and 1.00025.

(6) Connect digital multimeter to **TI DEMOD** output (rear panel).

(7) Repeat (3) through (5) above. Calculated ratio will be between 0.99745 and 1.00255.

(8) Connect equipment as shown in figure 3. Set decade resistor to 47 k $\Omega$ .

(9) Press **TONE SELECT 90 Hz** pushbutton (all other **TONE SELECT** pushbuttons off) and enter a **DDM** setting of 0.045 into TI. Record digital multimeter indication.

**NOTE**

Proper **DDM** steps can be entered by pressing **FUNCTION/CONTROL STEP ΔRDL ΔDDM** pushbutton.

(10) Press **TONE SELECT 150 Hz** pushbutton (all other **TONE SELECT** pushbuttons off). Record digital multimeter indication

(11) Divide value recorded in (10) above by the value recorded in (9) above. Calculated ratio will be between 1.11864 and 1.11979.

(12) Repeat technique of (9) through (11) above for each **DDM** setting listed in table 10. Calculated ratio will be within limits specified.

Table 10. Glideslope DDM

Test instrument DDM settings	Calculated ratio limits	
	Min	Max
0.091	1.25606	1.25733
0.175	1.55918	1.56082
0.400	2.99800	3.00200

(13) Press **STD, RDL/DDM**, enter **0.045 DDM** into TI, and then press **T/F U/L D/R** pushbuttons.

(14) Repeat technique of (9) through (12), except to calculate ratio, divide value recorded in (9) above by value recorded in (10) above.

**b. Adjustments.** No adjustments can be made.

**17. AM Modulation**

**NOTE**

Throughout this performance check, press **TONE SELECT** pushbutton as instructed. All other **TONE SELECT** pushbuttons must be off.

**a. Performance Check**

(1) Connect measuring receiver to TI **RF OUT**.

(2) Enter a frequency of 110.10 MHz into TI.

(3) Press **TONE SELECT 90 Hz** pushbutton.

(4) Press **FUNCTION/CONTROL %MOD** pushbutton and enter a modulation of 20 into TI.

(5) Enter an **RF LEVEL** of -6 dBmW into TI. If measuring receiver does not indicate between 19.5 and 20.5 percent amplitude modulation, perform **b** (1) below.

(6) Enter a frequency of 113.00 MHz and a modulation of 30 into TI.

(7) Press **TONE SELECT 30 Hz** pushbutton. If measuring receiver does not indicate between 29.25 and 30.75 percent, perform **b** (2) below.

(8) Press **TONE SELECT 9960 Hz** pushbutton. Measuring receiver will indicate between 29.25 and 30.75 percent.

## **TB 9-6625-2076-35**

(9) Enter a frequency of 332.00 MHz and a modulation of 40 into TI.

(10) Press **TONE SELECT 90 Hz** pushbutton. If measuring receiver does not indicate between 39.00 and 41.00 percent, perform **b** (3) below.

(11) Enter a frequency of 75.00 MHz and a modulation of 95 into TI.

(12) Press **TONE SELECT 1300 Hz** pushbutton. If measuring receiver does not indicate between 90.25 and 99.75 percent, perform **b** (4) below.

### **b. Adjustments (fig. 1a)**

(1) Adjust R2 for an indication of 20 percent on measuring receiver (R).

(2) Adjust R4 for an indication of 30 percent on measuring receiver (R).

(3) Adjust R3 for an indication of 40 percent on measuring receiver (R).

(4) Adjust R1 for an indication of 95 percent on measuring receiver (R).

## **18. Power Supply**

### **NOTE**

Do not perform power supply check if all other parameters are within tolerance.

**a. Performance Check.** Connect digital multimeter to **A2A3J1-8** and **chassis ground**. If digital multimeter does not indicate between 4.5 and 5.5 V dc, perform **b** below.

**b. Adjustment.** Adjust R2 (located on power supply PCB assembly **A5A2**) for a 5.0 V dc indication.

## **19. Final Procedure**

**a.** Deenergize and disconnect all equipment.

**b.** Annotate and affix DA label/form in accordance with TB 750-25.



**By Order of the Secretary of the Army:**

Official:



JOEL B. HUDSON  
*Administrative Assistant to the  
Secretary of the Army*

0320401

***PETER J. SCHOOMAKER***  
*General, United States Army*  
*Chief of Staff*

Distribution:

To be distributed in accordance with IDN 342219 requirements for calibration procedure  
TB 9-6625-2076-35.



### Instructions for Submitting an Electronic 2028

The following format must be used if submitting an electronic 2028. The subject line must be exactly the same and all fields must be included; however, only the following fields are mandatory: 1, 3, 4, 5, 6, 7, 8, 9, 10, 13, 15, 16, 17, and 27.

From: "Whomever" [whomever@redstone.army.mil](mailto:whomever@redstone.army.mil)

To: <2028@redstone.army.mil

Subject: DA Form 2028

1. **From:** Joe Smith
2. **Unit:** home
3. **Address:** 4300 Park
4. **City:** Hometown
5. **St:** MO
6. **Zip:** 77777
7. **Date Sent:** 19-OCT-93
8. **Pub no:** 55-2840-229-23
9. **Pub Title:** TM
10. **Publication Date:** 04-JUL-85
11. **Change Number:** 7
12. **Submitter Rank:** MSG
13. **Submitter FName:** Joe
14. **Submitter MName:** T
15. **Submitter LName:** Smith
16. **Submitter Phone:** 123-123-1234
17. **Problem:** 1
18. **Page:** 2
19. **Paragraph:** 3
20. **Line:** 4
21. **NSN:** 5
22. **Reference:** 6
23. **Figure:** 7
24. **Table:** 8
25. **Item:** 9
26. **Total:** 123
27. **Text**

This is the text for the problem below line 27.

